

AG7712\_2 FADER SLAVE (MOTOR)  
ALLEN & HEATH Ltd

UL 94U-0

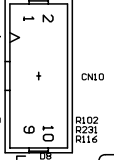

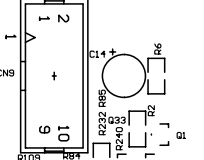
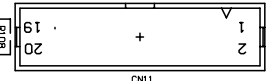
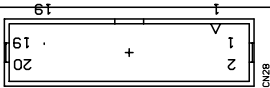
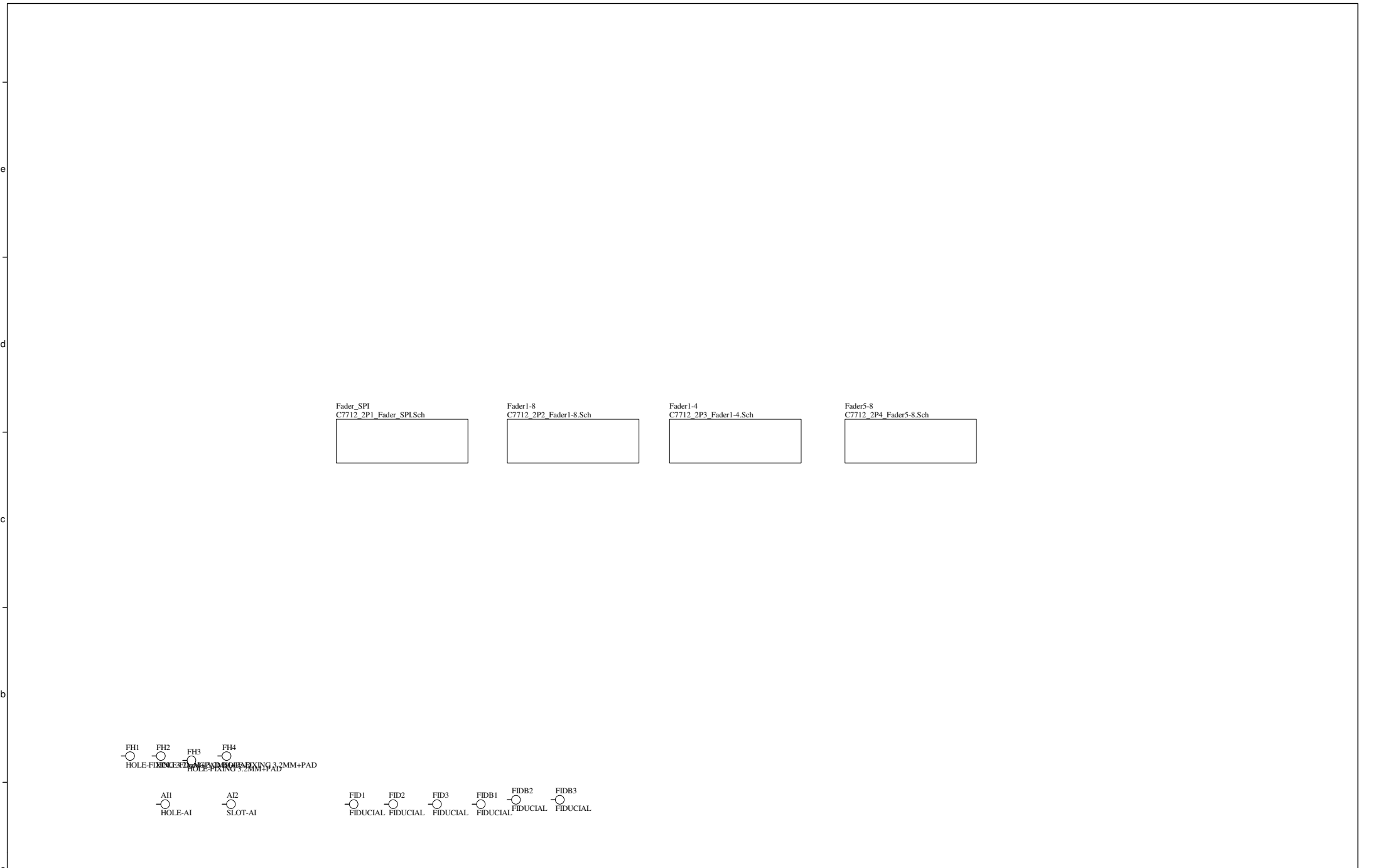

Fader\_SPI  
C7712\_2P1\_Fader\_SPLSch



Fader1-8  
C7712\_2P2\_Fader1-8.Sch



Fader1-4  
C7712\_2P3\_Fader1-4.Sch



Fader5-8  
C7712\_2P4\_Fader5-8.Sch



FH1 HOLE-FIDUCIAL  
FH2 HOLE-FIDUCIAL  
FH3 HOLE-FIDUCIAL  
FH4 HOLE-FIDUCIAL  
G1 ORIGINAL MARKING 3.2MM+PAD  
G2 ORIGINAL MARKING 3.2MM+PAD

A11 HOLE-AI  
A12 SLOT-AI

FID1 FIDUCIAL  
FID2 FIDUCIAL  
FID3 FIDUCIAL  
FIDB1 FIDUCIAL  
FIDB2 FIDUCIAL  
FIDB3 FIDUCIAL

**ALLEN&HEATH**

Kernick Industrial Estate,  
Penryn, Cornwall  
England. TR10 9LU  
Tel: +44 (0)1326 372070  
Fax: +44 (0)1326 370153

ISSUE	BY	DATE	CHK BY
A	GWR	25/06/09	XXX
C	MG	05/05/10	XXX
1	AAT	09/08/10	XXX
2	AAT	07/09/10	XXX

FILE: C7712_2P0_Sch		PRINTED: 14:15:09 22-Oct-2010	
---------------------	--	-------------------------------	--

\* All parts to be RoHS Compliant <sup>31</sup>

TITLE: GS-R24 FADER SLAVE (MOTOR)

PAGE:

DRG No: C7712 ISSUE: 2 SHEET: 0 OF 4

A B C D E F G H



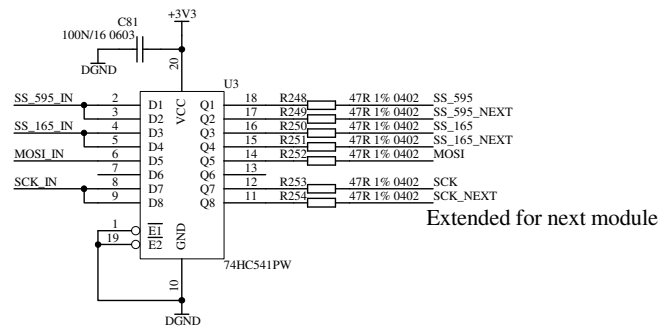

Extended for next module

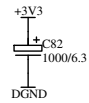
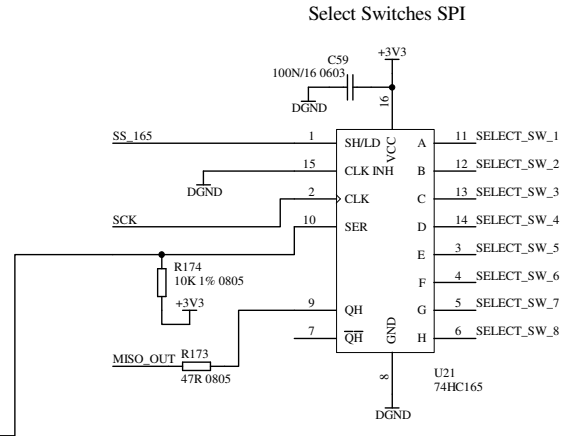
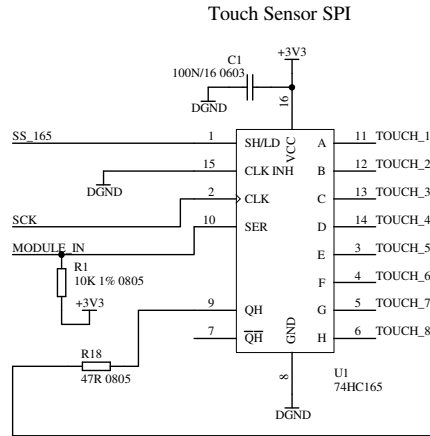

Enable circuit going to Level Shifter -15V

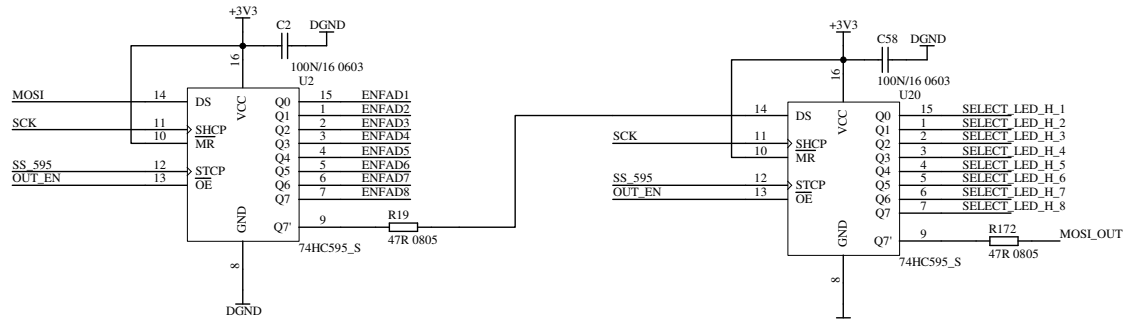

Extended for next module

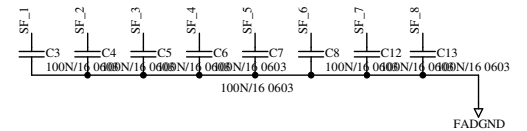

**ALLEN&HEATH**

Kernick Industrial Estate,  
Penryn, Cornwall  
England. TR10 9LU

Tel: +44 (0)1326 372070  
Fax: +44 (0)1326 370153

ISSUE	BY	DATE	CHK BY
A	GWR	25/06/09	XXX
C	MG	05/05/10	XXX
1	AAT	09/08/10	XXX
2	AAT	07/09/10	XXX

FILE: C7712\_2P1\_Fader\_SPI.Sch

\* All parts to be RoHS Compliant

PRINTED: 14:15:09 22-Oct-2010

TITLE: **GS-R24 FADER SLAVE (MOTOR)**

PAGE:

DRG No: **C7712** ISSUE: **2** SHEET: **1** OF **4**

### Level Shifter for Enable Circuit 1-8

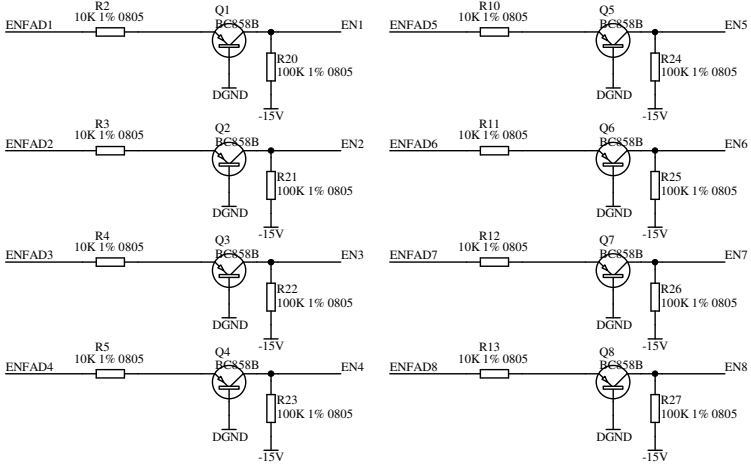
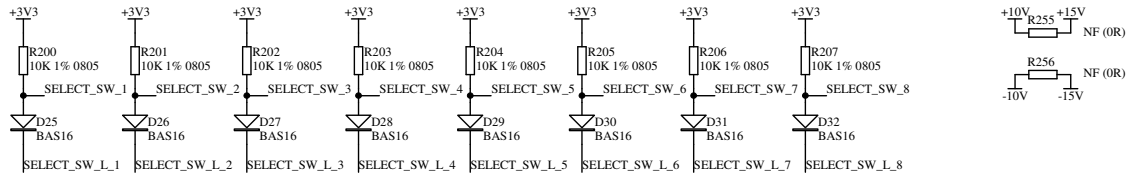
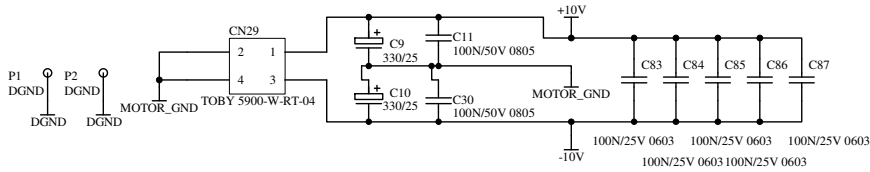

### Conector

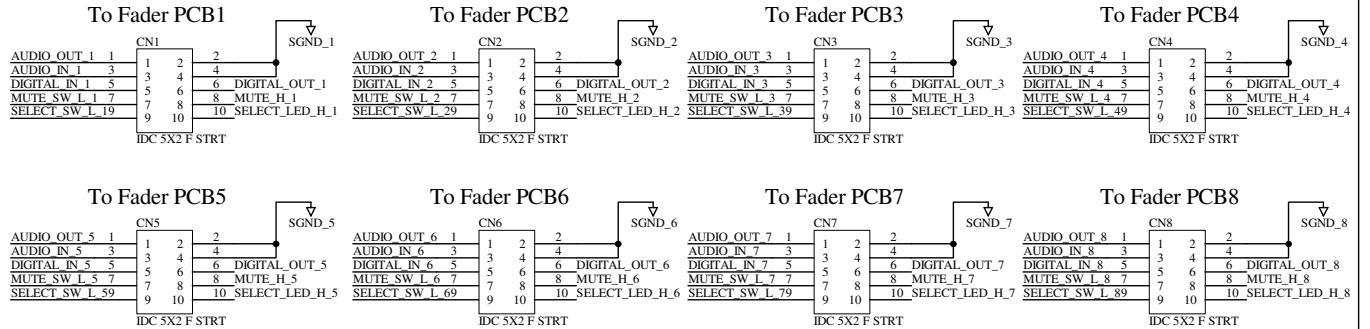

### Sample Hold Circuit 1-8

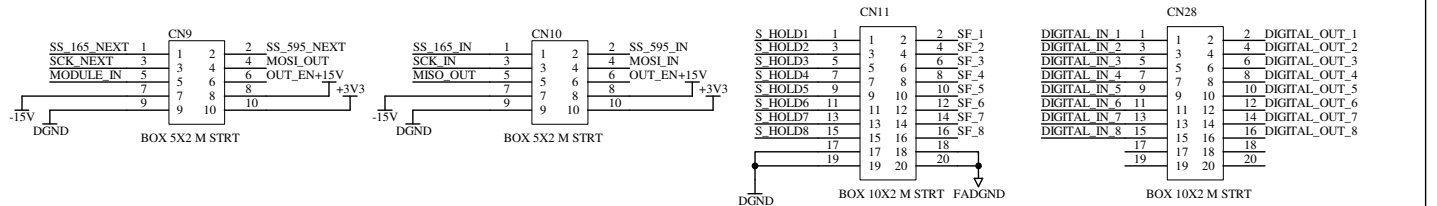
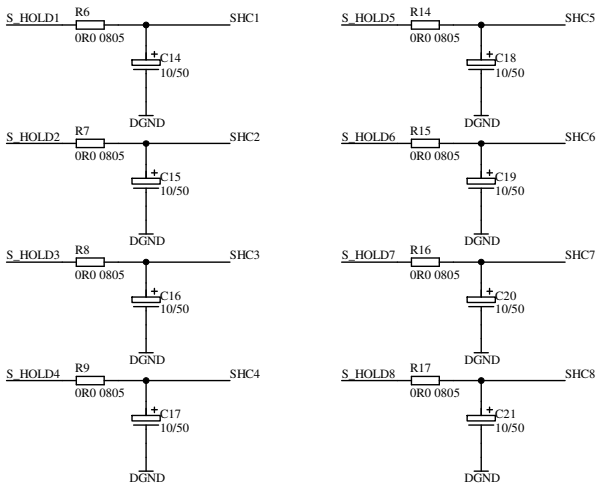

### Faders 1-8

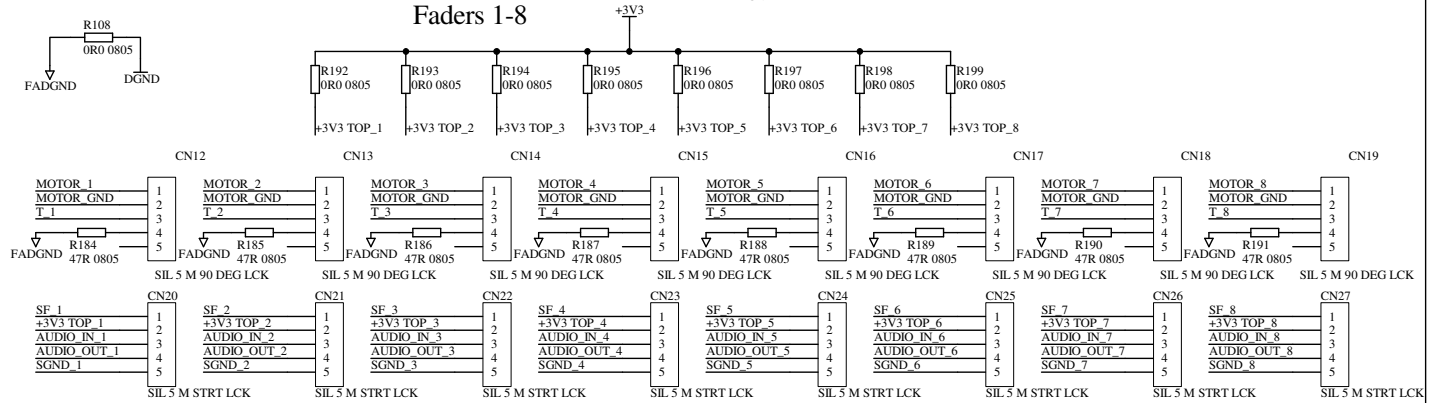

**ALLEN&HEATH**

Kernick Industrial Estate,  
Penryn, Cornwall  
England. TR10 9LU  
Tel: +44 (0)1326 372070  
Fax: +44 (0)1326 370153

ISSUE	BY	DATE	CHK BY
A	GWR	25/06/09	XXX
C	MG	05/05/10	XXX
1	AAT	09/08/10	XXX
2	AAT	07/09/10	XXX

FILE: C7712\_2P2\_Fader1-8.Sch

\* All parts to be RoHS Compliant \*

PRINTED: 14:15:09 22-Oct-2010

TITLE: GS-R24 FADER SLAVE (MOTOR)

PAGE:

DRG No: C7712 ISSUE: 2 SHEET: 2 OF 4

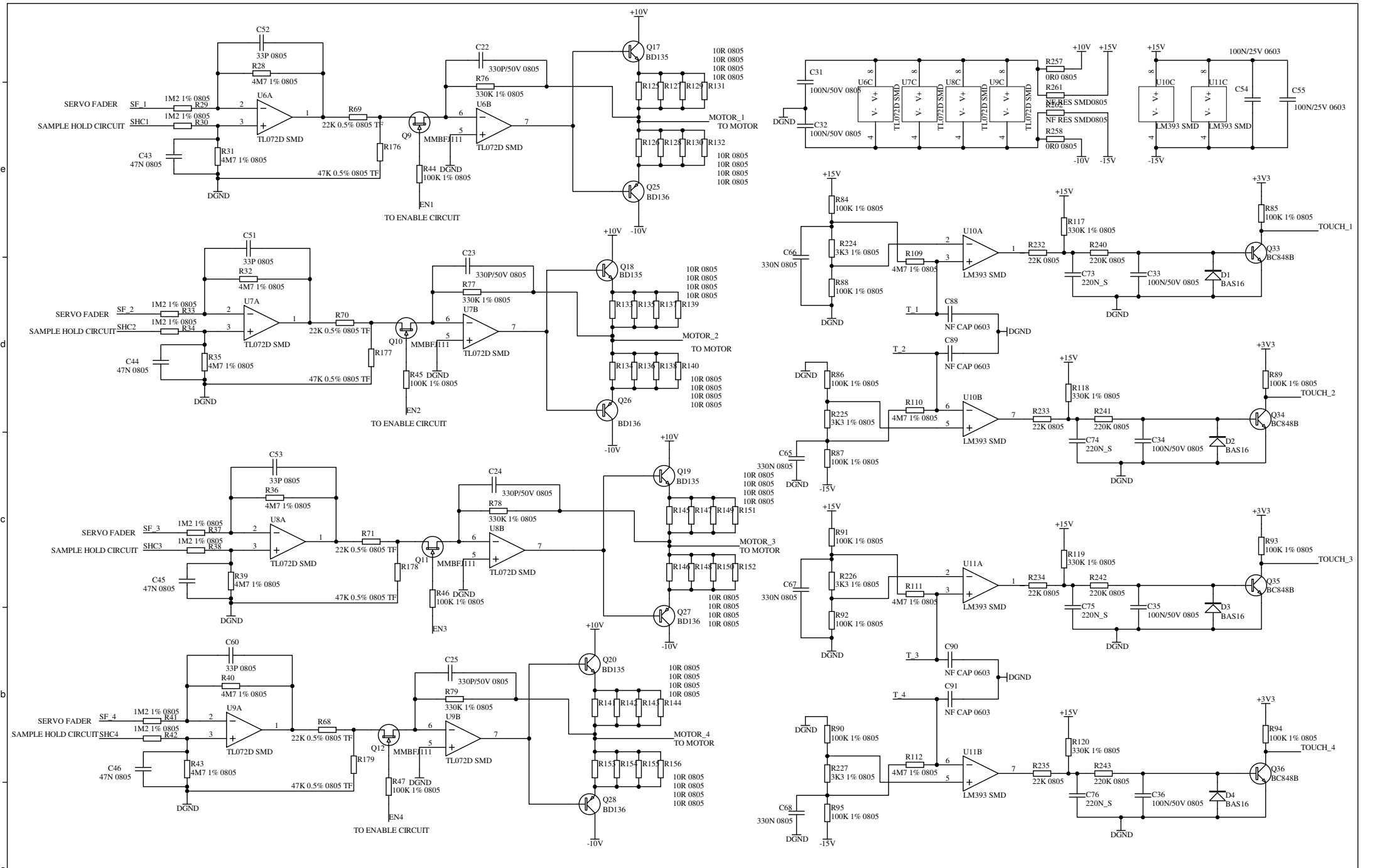

**ALLEN&HEATH**  
 Kernick Industrial Estate,  
 Penryn, Cornwall  
 England, TR10 9LU  
 Tel: +44 (0)1326 372070  
 Fax: +44 (0)1326 370153

ISSUE	BY	DATE	CHK BY
A	GWR	25/06/09	XXX
C	MG	05/05/10	XXX
1	AAT	09/08/10	XXX
2	AAT	07/09/10	XXX

FILE: C7712\_2P3\_Fader1-4.Sch

TITLE: **GS-R24 FADER SLAVE (MOTOR)**  
 PAGE:  
 \* All parts to be RoHS Compliant \*  
 DRG No: **C7712** ISSUE: **2** SHEET: **3** OF **4**  
 PRINTED: 14:15:10 22-Oct-2010

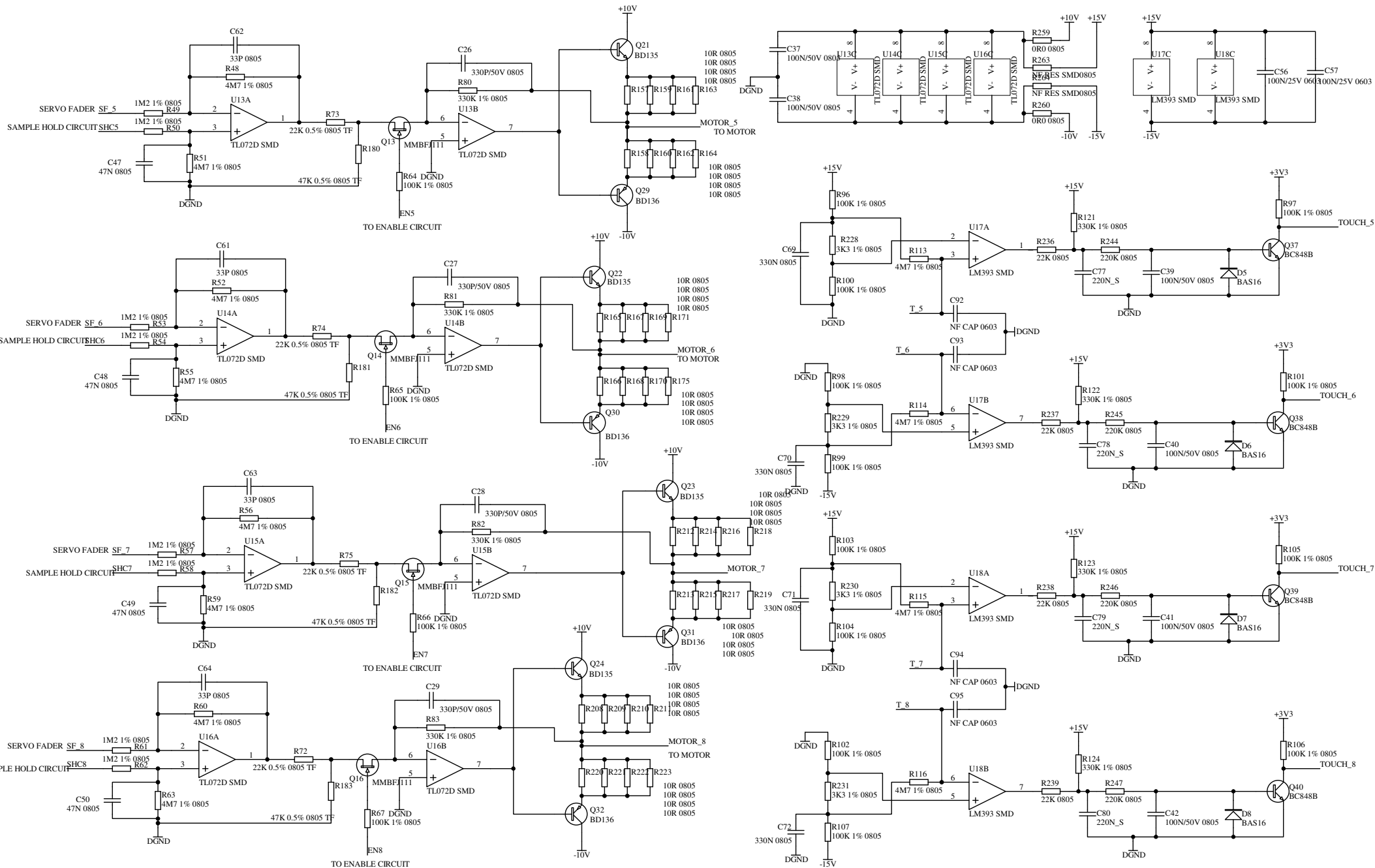

**ALLEN&HEATH**

Kernick Industrial Estate,  
Penryn, Cornwall  
England, TR10 9LU

Tel: +44 (0)1326 372070  
Fax: +44 (0)1326 370153

ISSUE	BY	DATE	CHK BY
A	GWR	25/06/09	XXX
C	MG	05/05/10	XXX
1	AAT	09/08/10	XXX
2	AAT	07/09/10	XXX

FILE: C7712\_2P4\_Fader5-8.Sch

\* All parts to be RoHS Compliant \*

TITLE: GS-R24 FADER SLAVE (MOTOR)

PAGE:

PRINTED: 14:15:10 22-Oct-2010

DRG No: C7712 ISSUE: 2 SHEET: 4 OF 4